



**FASTER**



**GREENER**



**SMARTER**



**RELIABLE**

**MPH200<sup>2</sup>**



**SACMI**

Powder Metal Solutions

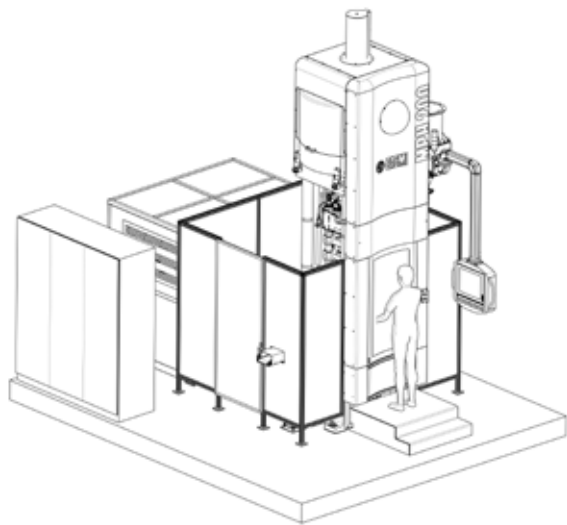
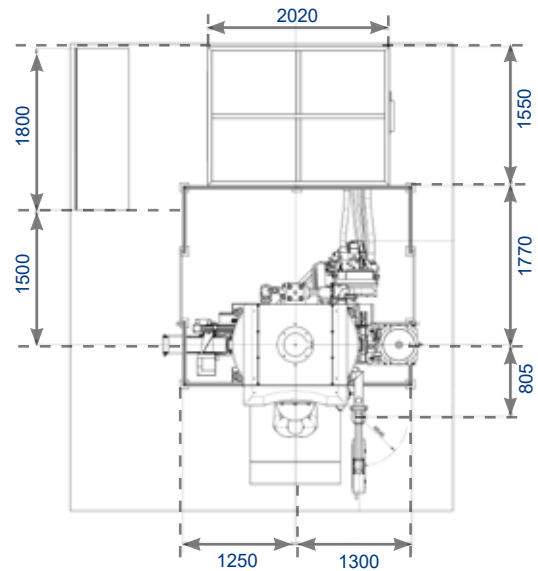
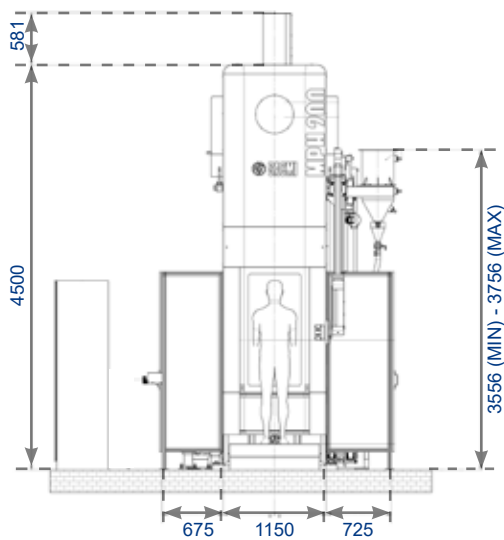

# MPH200<sup>2</sup>

FULLY AUTOMATIC CNC PROGRAMMABLE  
HYDRAULIC PRESS FOR  
POWDER METAL COMPACTION

PRESSA IDRAULICA AUTOMATICA  
PER POLVERI METALLICHE

CNC-GEREGLTE HYDRAULISCHE  
PULVERPRESSE

## TECHNICAL DATA - DATI TECNICI - TECHNISCHE DATEN

Max pressing force Massima forza di compattazione Max. Presskraft	kN	2,000	Die-set lower levels stroke (Y1 – Y2 – Y3) Corsa punzoni inferiori (Y1 – Y2 – Y3) Hub unteren Zusatzachsen (Y1 – Y2 – Y3)	mm	65
Hydraulic oil volume Volume di olio idraulico Ölmenge	l	1,000	Die-set core rod stroke (Z1) Corsa spina (Z1) Hub Mittelstift (Z1)	mm	130
Installed power up to Potenza installata fino a Installierte Gesamtleistung bis zu	kW	128	Die-set maximum filling height (Z) Massima altezza di caricamento (Z) Max. Füllhöhe (Z)	mm	130
Total weight (with die-set) Peso totale (con adattatore) Gesamtgewicht (inkl. Adaptor)	Kg	14,000	Maximum die counterforce (Z) Massima controforza tavola porta matrice (Z) Max. Gegenhaltekraft (Z)	kN	1,000
Die-set upper levels stroke (X1 – X2 – X3) Corsa punzoni superiori (X1 – X2 – X3) Hub obere Zusatzachsen (X1 – X2 – X3)	mm	50	Maximum die ejection force (Z) Massima forza di estrazione (Z) Max. Abzugskraft (Z)	kN	600



SACMI IMOLA S.C.  
Via Selice Prov.le, 17/A - 40026 Imola Bo - ITALY  
Tel. +39 0542 607111 - powdermetal@sacmi.it  
www.sacmi.com

